

NOTES: UNLESS OTHERWISE SPECIFIED

1. SEE DRAWING NO. CB-00303 AND PROCEDURE P-1000 FOR ASSEMBLY AND TEST INSTRUCTION. PROCEDURES AND ASSEMBLY DRAWINGS ARE FOR INTERNAL USE ONLY.
2. ALL TESTING ARE IAW BATTERY COUNCIL INTERNATIONAL STANDARDS.
3. ALL DIMENSIONS ARE IN INCHES [MM].
4. ABBREVIATION USED IN TITLE IS: SEALED LEAD ACID (SLA).

REVISIONS			
REV	DESCRIPTION	DATE	APPROVED
A	REDESIGNED CONTAINER, COVER	4/2/02	JBT

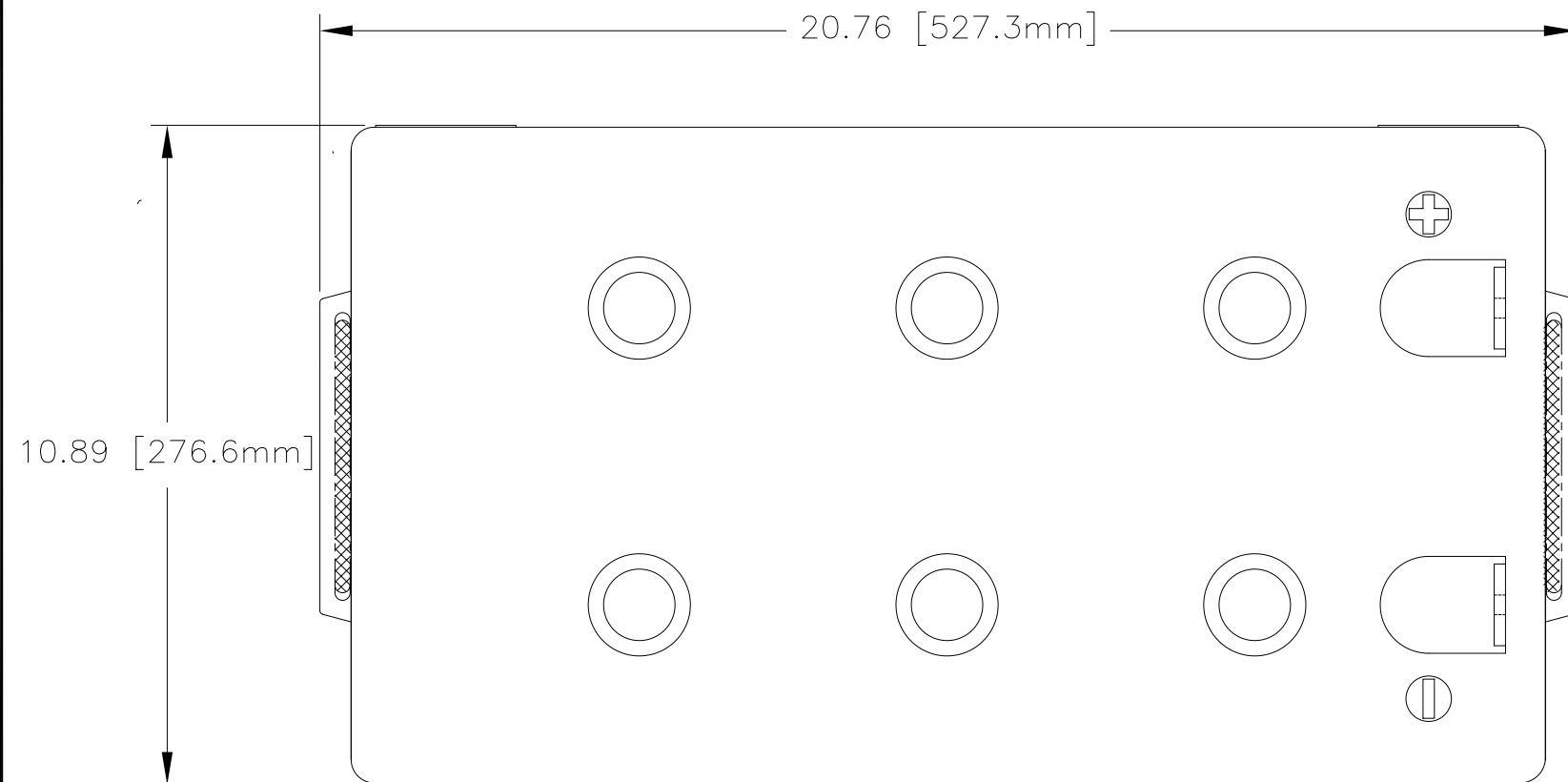

NOTE: SEE OPTIONS LISTED

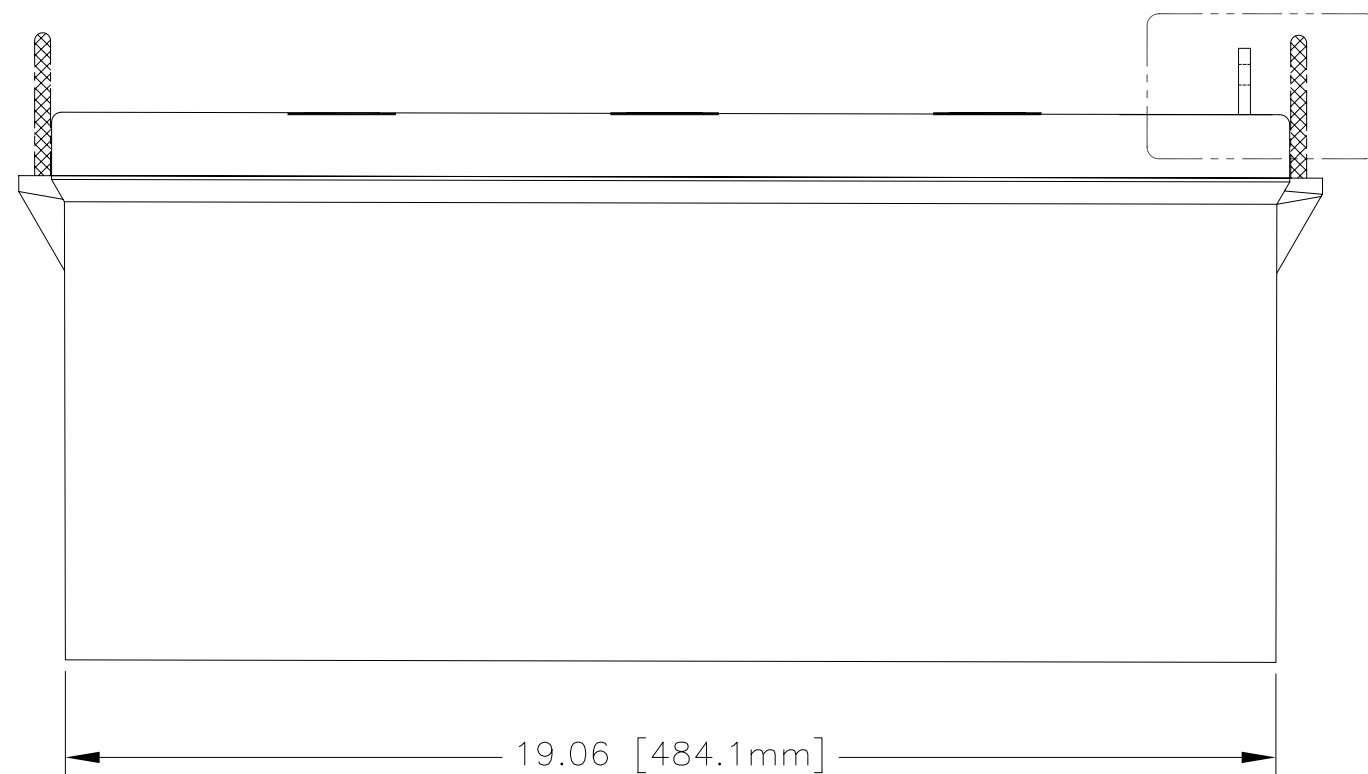

PVX-2580 TERMINAL OPTIONS

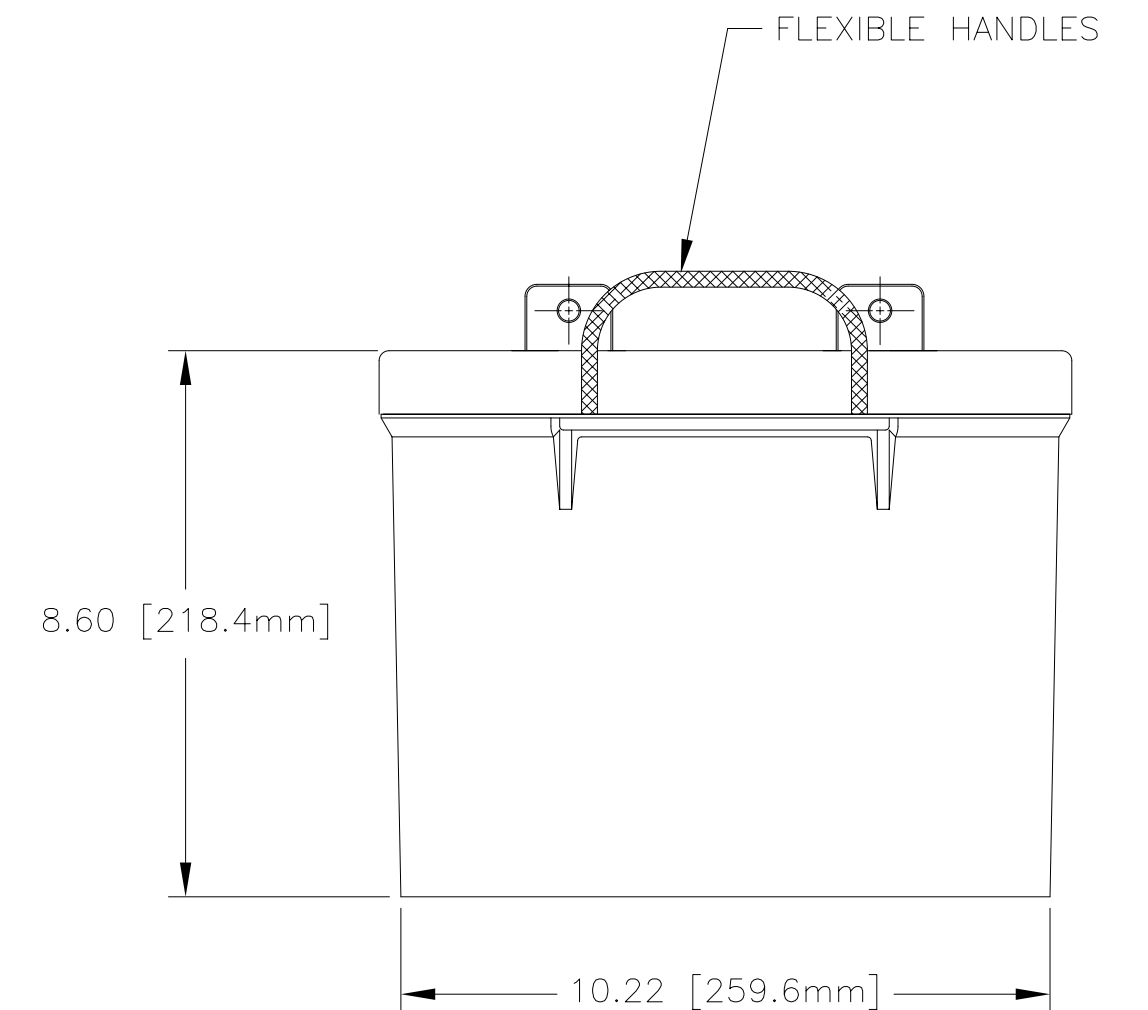
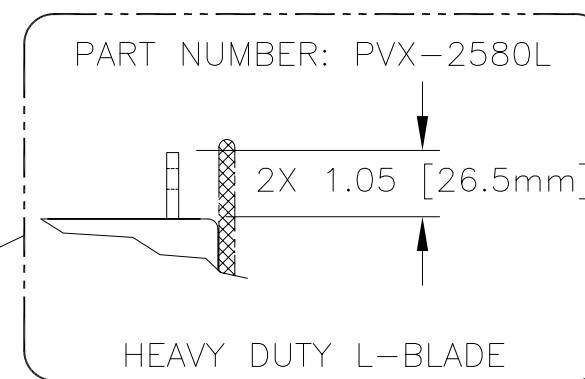

CAPACITY RATINGS	
PART NUMBER	PVX-2580
NOMINAL WEIGHT	165 LBS[75 KG]
AMPERE HOUR CAPACITY @ 24 HOUR 1.75 VOLTS/CELL @ 77°F (25° C)	258 AH

ENVELOPE DRAWING

QTY REQD	CAGE CODE	PART OR IDENTIFYING NO.	NOMENCLATURE OR DESCRIPTION	MATERIAL SPECIFICATION	ITEM NO.
PARTS LIST					
UNLESS OTHERWISE SPECIFIED DIMENSIONS ARE IN INCHES TOLERANCES ARE:			CONCORDE BATTERY CORPORATION 2009 SAN BERNARDINO RD, W. COVINA, CA 91790		
FRACTIONS	DECIMALS	ANGLES	TITLE BATTERY, SLA, 12 VOLT, PVX-2580		
± 1/32	.XX ± .06	± 1°	APPROVALS	DATE	REV
	.XXX ± .030		DRAWN ELH	8/13/01	A
TREATMENT	NONE	CHECKED HRF	8/21/01	SIZE	CAGE CODE
FINISH	NONE	APPROVED JBT	8/23/01	C	63017
SIMILAR TO NA	ACT WT NA	CALC WT NA	ISSUED AT	DWG NO.	PVX-2580
			4/5/02	SCALE	NONE
				SHEET	1 OF 1